

This drawing remains our property and may not be copied or passed on to a third party without our written permission. We reserve the right for changes at any time without previous notice.

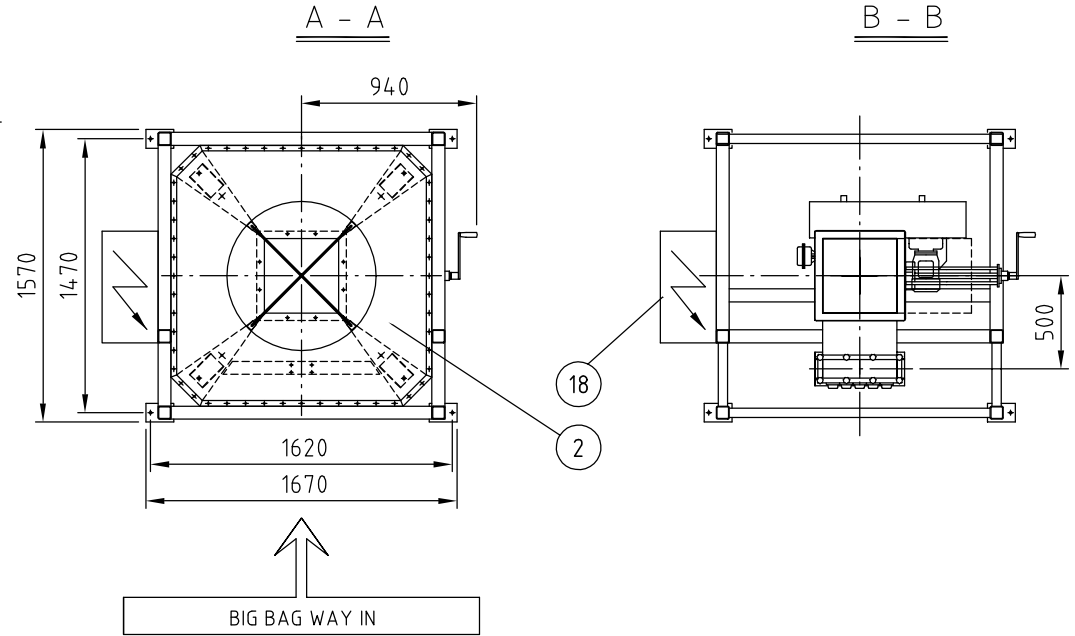
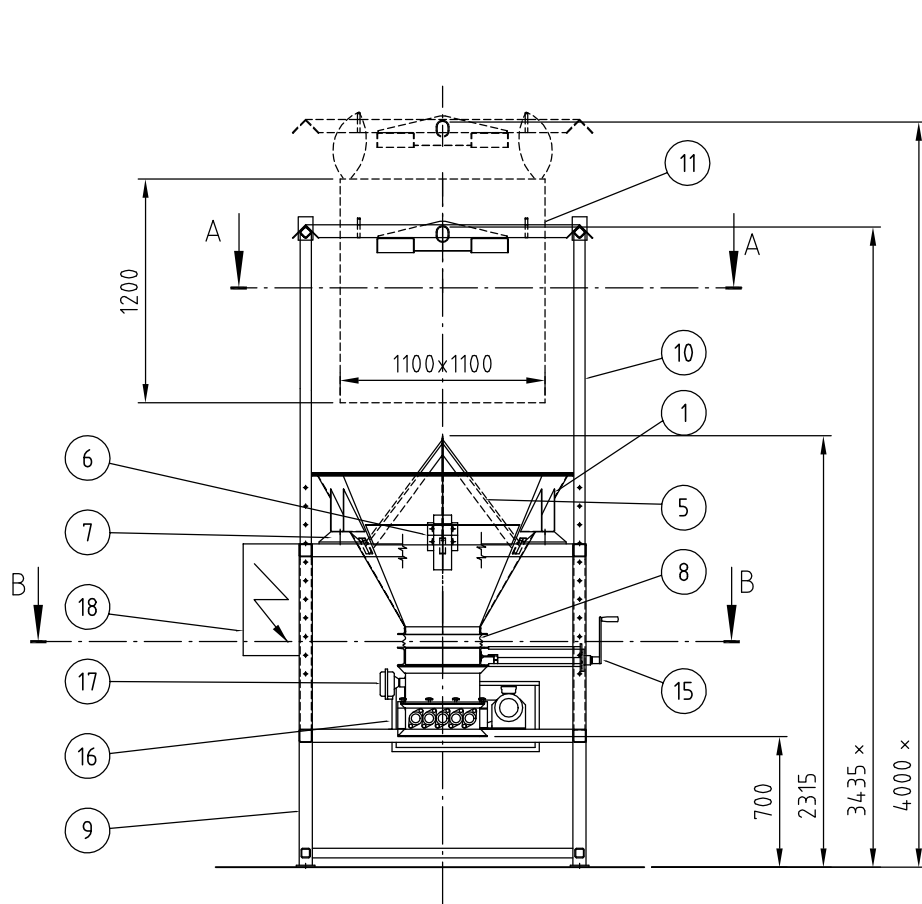

DIMENSIONS MARKED THUS "X" ARE DEPENDANT ON THE SIZE OF THE BIG-BAG USED

18	1	Electrical cabinet			
17	1	Empty level- / Arch indicator			
16	1	Feeder		405	
15	1	Shut-off damper valve		400	
11	1	Yoke			Option
10	1	Upper stand			
9	1	Lower stand			
8	1	Flexible connection			
7	4	Vibration damper			
6	1	Vibrator		HV 2/4 - 9	
5	1	Pyramid knife			
2	1	Rubber sealing cloth			
1	1	Big-Bag cone			
Def.No.	Qty	Denomination	Material	Modell or Dimension	Remark

Constructed	HG	Drawn	HG	Copy	Controlled	TC	Standard	Approved	TC	Scale	1:40 - A4	Replaces	Replaced of
TOMAL® Big-Bag Discharger type 1100 Support stand with or without yoke Outlet 400x400, Disposable Big-Bag											010513	Date	
											Drawing No.	010513	

No.	Pcs.	Modification	Date	Intr.	Appr.
-----	------	--------------	------	-------	-------